

Item	Description	HP Part No.	Qty
1	Flow Manifold Block, TCD and ECD	19232- 20500	1
2	Restrictor, Blue Dot	19234- 60660	1
3	Restrictor, Red Dot	19231- 60770	1
4	O- ring	0905- 1014	2
5	Wye Brazement	19233- 80615	1
6	Rear Clamping Plate	19231- 40010	1
7	Machine Screw M4 x 0.7 x 12	0515- 09093	
8	Mounting Screw M4 x 45 mm long	0515- 0964	1
9	Hex Nut, Brass, 1/8- inch tube	0100- 0058	2
10	Back Ferrule, Brass, 1/8- inch tube	0100- 0036	2
11	Front Ferrule, Brass, 1/8- inch tube	0100- 0032	2
12	O- ring	0905- 1039	2
13	Outlet Fitting Plate	19231- 00060	1
14	Short Purge Brazement	19246-80520	1
15	Make- up Gas Adaptor	19233- 80565	1
16	Greased O- ring	5181- 1251	2
17	Non- Greased O- ring .208 id	0905- 0999	4
18	On/Off Valve	19231- 20540	2
19	Clamp Block	19231- 40070	1

**Figure 4. G1223A/G1224A ECD Flow Manifold Block Assembly (Sheet 1 of 2).**

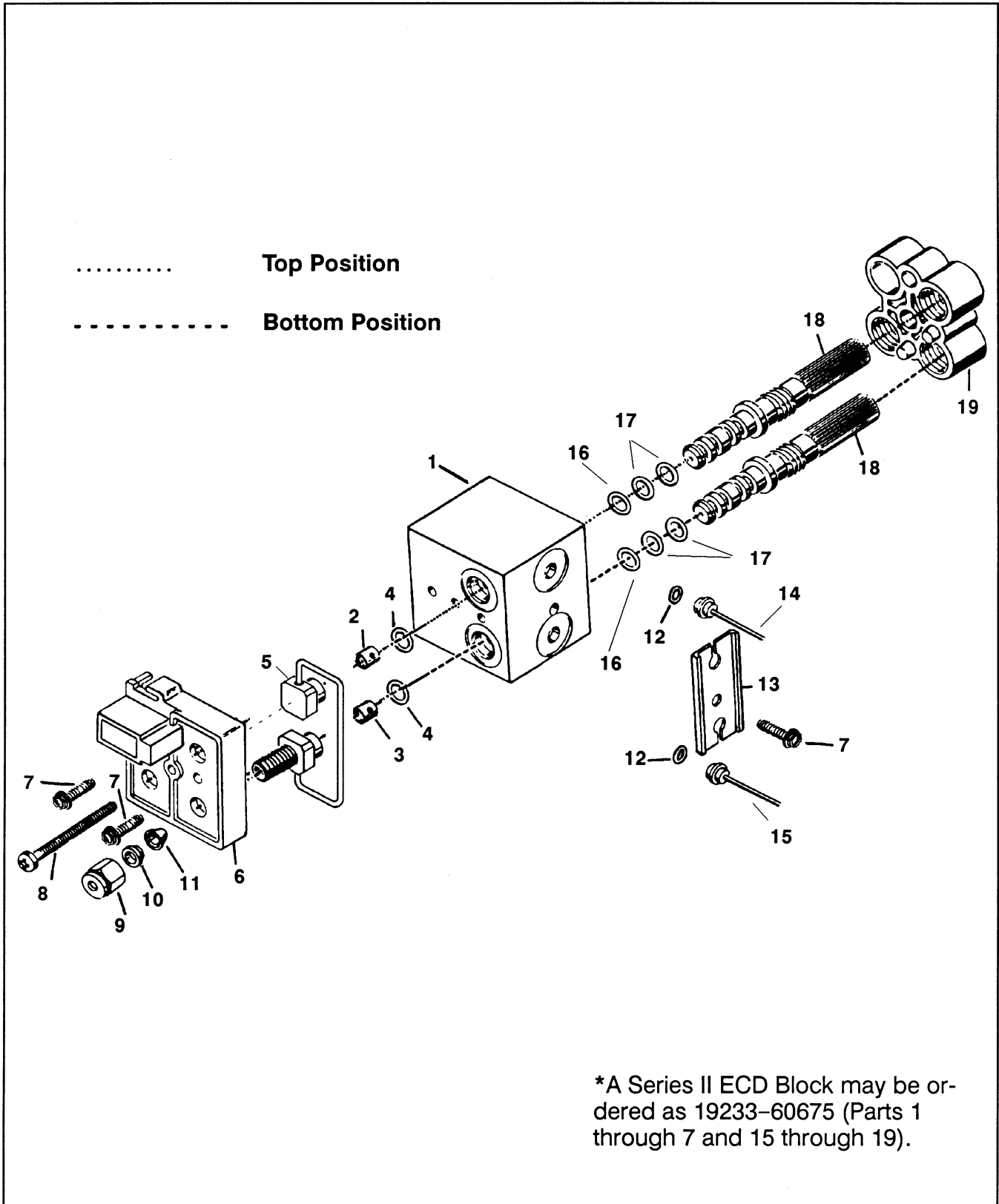

Figure 4. G1223A/G1224A ECD Flow Manifold Block Assembly (Sheet 2 of 2).